

## Knife gate valve

## DN 80-800

The Stafsjö XV knife gate valve is a compact bi-directional valve with full bore. The XV valve is specially designed with regard to good flow characteristics and simple maintenance which makes it suited for both liquids and dry media.

The XV valve is designed of a one piece valve body in stainless steel and a stainless steel gate. The retainer rings mechanically locks the seats, making them easy to replace. The unique Stafsjö box packing TwinPack™ gives high operation reliability.

Due to the flexible design of the XV valve, it can be provided with different types of manual and automatic actuators and accessories, such as limit switches.

The Stafsjö knife gate valve XV is designed, manufactured, inspected and tested according to the European directive Pressure Equipment Directive (PED 97/23/EC) category II module A1 and is therefore CE marked.





## Knife gate valve

## DN 80-800

DN	500	600	700	800
AUMA	SA 10.1	SA 10.1	SA 14.1	SA 14.1
Attachment	F10/A	F10/A	F14/A	F14/A

Electric motors are mounted according to standard ISO 5210. The table gives recommended motor sizes at normal operation. For other operating conditions, please contact Stafsjö or your local representative for advice.

For other actuators, please contact Stafsjö or your local representative for advice.

### Accessories

#### Limit switches

Mechanical	Ersce E100	
Inductive	ifm electronic IG-2008-ABOA / IG0006	2-wire 20-250 V AC/DC
	ifm electronic IG-3008-BPKG / IG5401	3-wire 10-36 V DC PNP

#### Accessories to pneumatic cylinder

Solenoid valve	Metal Work SOV 35 SOS OO	1/4"
	Metal Work SOV 45 SOS OO	1/2"
Magnetic limit switch	Elobau 102 247	2-wire 10-250 V AC/DC
	Elobau 102 290 PE	3-wire 10-30 V DC

For advice regarding accessories, please contact Stafsjö or your local representative.

### Pressure tests

Pressure tests are performed with water at 20°C according to ISO 5208 meaning:

1,5 x maximum working pressure for open valve – shell test

1,1 x maximum differential pressure for closed valve – obturator tightness test

### Leakage rate

Rate A according to ISO 5208 – no visible leakage for the duration of the test

### Weight, valve incl. hand wheel (HW)

DN	80	100	125	150	200	250	300	350	400	500	600	700	800
kg	8	10	13	15	30	41	57						

### Materials – corresponding foreign materials

Stafsjö standard	Type of material	Sweden		Germany		USA			England	Japan
		SS	W. Nr.	DIN	ASTM	AISI	UNS	BS	JIS	
A2	Stainless	SS2333	W1.4301	X5CrNi18 M 10		304	S30400	304S15	SUS 304	
AISI 304	Stainless	AISI 304	W1.4301	X5CrNi18 M 10		304	S30400	304S15	SUS 304	
EN AW-6063-T6	Aluminium	EN AW-6063-T6		AlMgSi 0,5	AA 6063					
GG25	Cast iron	SS0125-00	0.6025	GG 25	A 48 No 40 B			Grade 260	FC 250	
GGG50	Nodular iron	SS0727	0.7050	GGG 50				Grade 500/7	FCD 500	
SS0120-00	Cast iron	SS0120-00	0.6020	GG 20	A 48 No 30 B			Grade 220	FC 200	
SS1312	Carbon steel	SS1312		RSt 37-2	A 36			40 B		
SS2303-03	Stainless	SS2303-03	W1.4021	X20Cr13		420	S42010	420S37	SUS 420J1	
SS2320-02	Stainless	SS2320-02	W1.4016	X6Cr17		430	S43000	430S17	SUS 430	
SS2333-02	Stainless	SS2333-02	W1.4301	X5CrNi18 M 10		304	S30400	304S15	SUS 304	
SS2343-12	Stainless	SS2343-12	W1.4408	G-X6CrNiMo 18 10	A 743-91 CF-8M			316 C 16	SCS 14	
SS2343-28	Stainless	SS2343-28	W1.4436	X3CrNiMo17 13 3	A 240, Type 316			Gr 316 S 33		
SS2346-02	Stainless	SS2346-02	W1.4305	X10CrNiS 18-9		303		303S31	SUS303	
SS2347-02	Stainless	SS2347-02	W1.4401	X5CrNiMo17 12 2		316	S31600	316S31	SUS 316	
SS2383-02	Stainless	SS2383-02	W1.4104	X12CrNiOS17		430 F	S43020		430 F	
SS5170-00	Brass	SS5170-00		CuZn39Pb3	C 36000			CZ 121		
SS2377-02	Stainless	SS2377-02	W1.4462	X2CrNiMoN22 5 3			S31803	318S13		
W1.4408	Stainless	W1.4408	W1.4408	G-X6CrNiMo 18 10	A 743-91 CF-8M			316 C 16	SCS 14	

### Knife gate valve

### DN 80-800

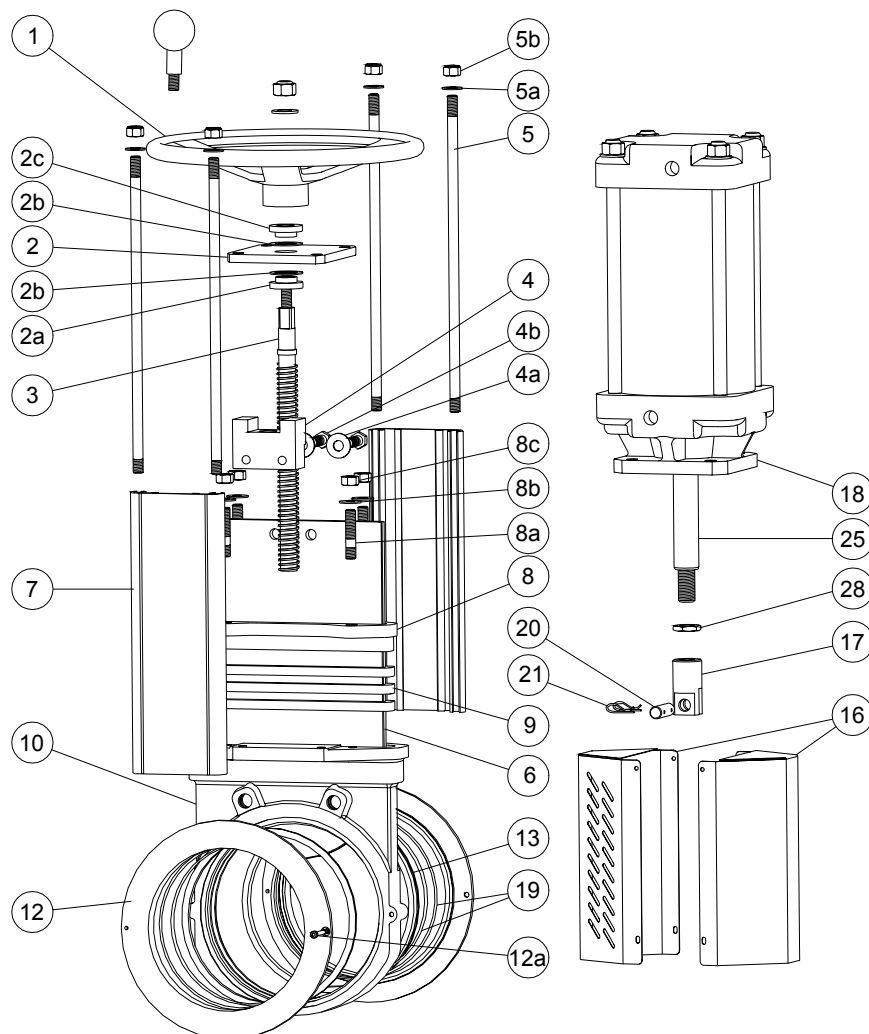

Pos	Part	Material
1	Hand wheel	Aluminium ENAC-AISI9Cu3(Fe), DN>300 Cast iron GG20
2	Yoke	Stainless steel SS2333-02
2a	Bearing	Brass SS5170-00
2b	Slide washer	POM
2c	Bearing	Brass SS5170-00
3	Stem	Stainless steel DN50-250 SS2320-02, DN>250 SS2383-02
4	Stem nut	Brass SS5170-00
4a	Washer	A2
4b	Screw	A2
5	Tie rod	Stainless steel SS2333-02
5a	Washer	A2
5b	Nut	A2
6	Gate	See equipment B
7	Beam	Aluminium EN AW-6063-T6
8	Gland	Stainless steel SS2343
8a	Stud bolt	A2 + zinc

Pos	Part	Material
8b	Washer	A2
8c	Nut	A2 + zinc
9	Box packing*	See equipment E
10	Valve body	See equipment A
12	Retainer ring	See equipment C
12a	Locking screw	A2
13	Seat*	See equipment D
16	Gate guard, not for HW	Stainless steel SS2333-02,
17	Gate clevis	Stainless steel SS2346-02
18	Cylinder	See data sheet
19	O-ring	See equipment D
20	Clevis pin	Stainless steel SS2346-02
21	Split pin	Stainless steel SS2343-02
25	Piston rod	Stainless steel SS2383-02
28	Locking nut	Stainless steel SS2346-02

\* Recommended spare parts

### Knife gate valve

### DN 80-800

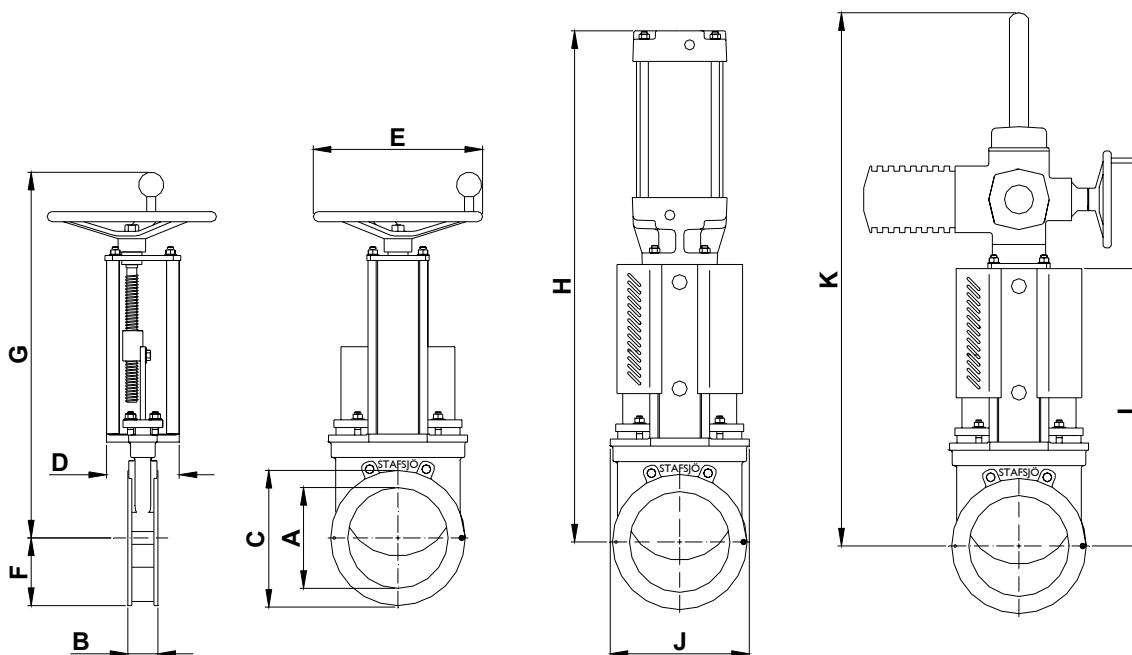

#### Dimensions (mm)

DN	80	100	125	150	200	250	300	350	400	500	600
A	80	100	125	150	200	250	300	350	400	500	600
B	46	52	56	56	60	68	78	78	89	114	114
C	138	158	188	212	269	322	372	432	481	586	686
D	80	80	80	80	145	145	145	175	175	250	260
E	200	200	200	200	315	315	315	400	400	520	635
F	69	79	94	106	134,5	161	186	216	241	302	343
G	444	482	523	567	691	785	879	1021	1116	1342	1546
H	582	620	711	755	1006	1100	1244	1477	1622	1988	2329
J	140	158	188	212	277	331	382	437	488	603	735
K	636	674	715	759	868	994	1149	1308	1453	1770	2076
L	314	352	393	437	546	640	734	841	936	1152	1356

Actuator EM is rotated 45° for DN 80-150.

DN	700	800
A	680	780
B	128	128
C	800	901
D	320	320
E	635	635
F	450	500
G	1650	1866
H	2475	2952
J	902	1002
K	2382	2697
L	1527	1742

